

Nautical Instruments User Manual



Before using products, please read this manual carefully, and retain it well for further reference.

Safety Instruction

Please read this safety instruction carefully before using the instrument. Important safety issues are herein listed for your concern.



This symbol is intended to alert the user that if this instruction is not properly followed, it is very likely to result in accident of death or GBH.



This symbol is intended to alert the user that if this instruction is not properly followed, it is possible to result in accident of death or GBH.



This symbol is intended to alert the user that if this instruction is not properly followed, it is possible to result in damage, loss or injury.



△ This symbol is intended to the **Notice Action**, and there is a mark of **Notice Action** in or near the symbol. (The example on the left is **SAFEKEEPING!**)



⊘ This symbol is intended to the **Forbidden Action**, and there is a mark of **Forbidden Action** in or near the symbol. (The example on the left is **NO TOUCH!**)



- This symbol is intended to the **Compulsory Action**, and there is a mark of the **Compulsory Action** in or near the symbol. (The example on the left is **TAKE THE BATTERY OUT**)



About the Instruments



If the liquid of battery leakage spills into one's eyes , wash the eyes immediately with clean water, and receiving treatment from doctor is highly necessary. Otherwise it may result in eye injury.



If the liquid of battery leakage spills over skin or clothing, wash it immediately with clean water. Otherwise it may result in inflammation of skin.



About the Instruments



**NO
DISASSEMBLING**

Do not disassemble, repair or refit the instrument by yourself, otherwise it may result in damage or injury.



NO TOUCH

Don't touch the broken glass and shattered part of the instrument with your hand when it fall down and is damaged, otherwise it may result in injury.



**COMMISSIONED
SERVICE**

Take the battery off (if there is one inside), then send the instrument to the commissioned agent for repairing.



**TAKE OUT
BATTERY**

Take out the battery immediately when heat, smoking or burning smell from the instrument is detected, otherwise it may result in fire .



**COMMISSIONED
SERVICE**

Take the battery off (if there is one inside), then send the instrument to the commissioned agent for repairing.



NO WET

For non-waterproof instrument, do not immerse it in water or shower bath by rain, otherwise it may result in short circuit or damage.



TAKE OUT BATTERY

Take out the battery immediately when the instrument is immersed in water or shower bath by rain, otherwise it may result in fire.



COMMISSIONED SERVICE

Take the battery off (if there is one inside), then send the instrument to the commissioned agent for repairing.



FORBIDDING USE

Do not use the instrument with battery under occasions where there is propane, gasoline and other flammable or explosive gas or dust, otherwise it can result in exploding or fire.



SAFEKEEPING

Do not keep the instrument within reach of children, otherwise small parts of the instrument may be swallowed by children.



NOTICE

About the Instruments



SAFEKEEPING

Do not keep the instrument within reach of children, otherwise it may result in injury.



USE CAUTION

Do not strike the instrument, otherwise it may be damaged.



BEWARE OF GLASS

Do not strike the instrument, otherwise the cracked glass may cut hand.



USE CAUTION

Remove the battery immediately when low-voltage, as it may leak acid causing damage to movements and human body.



TAKE OUT BATTERY

Take out battery when in storage. Otherwise it could become dead and leak acid causing damage to movement.



DANGER

About the Battery



DANGER

If the liquid of battery leakage spills into one's eyes, wash the eyes immediately with clean water, and receiving treatment from doctor is high necessary. Otherwise it may result in eye injury.



DANGER

If the liquid of battery leakage spills over skin or clothing, wash it immediately with clean water. Otherwise it may result in inflammations of skin.



WARNING

About the Battery



**FIRE
PROHIBITION**

Do not put the battery into fire or heat it. Otherwise it may leak acid, heat or crack.



**NO
DISASSEMBLING**

Do not disassemble the battery or make it short circuit. Otherwise it may leak acid, heat or crack.



Please comply with the cautions and notice marked on the battery. Otherwise it may leak acid, heat or crack.



Do not scathe and tear off the battery tegmen. In addition, do not use the battery whose tegmen has been scathed or tore off. Otherwise it may leak acid, heat or crack.



SAFEKEEPING

Do not keep the battery within reach of children. Otherwise it may be swallowed by children.



Do not install the battery in wrong direction, Do not confuse (+),(-) pole of the battery. Otherwise it can leak acid, heat or crack.



NO WET

Do not allow the battery be immersed in water or to come into contact with water. Otherwise it can leak acid, heat or crack.



NO CHARGE

Do not charge the un rechargeable battery. Otherwise it can leak acid, heat or explode.



TAKE OUT BATTERY

Take out battery immediately when the power of battery gives out. Otherwise it may leak acid, heat, or crack.



WARNING

Insulate the poles of the battery by adhesive tape when discarding the battery. Please comply with the local laws when discarding battery.



WARNING

If the liquid of battery leakage spills over skin or clothing, wash it immediately with clean water. otherwise it may result in inflammations of skin.

Table of contents

Safety Instructions	2
Installation Instructions	12
How to install the instruments with hinged bezel.....	12
How to install the instruments with fixed glass lens.....	13
How to calibrate horizontal line and vertical line	16
Quartz Clock Instructions	18
Operating Precautions	18
Operating Instruction of Clock with hinged bezel	21
Operating Instruction of Clock with fixed glass lens.....	23
Function Instructions	26
General quartz clock	26
Signal flag numerals dial clock.....	27
24 hour time/Military time clock.....	28
Radio room clock.....	30
Time & Tide clock	32

Barometer Instructions 35

General Instructions 35

Instruction of calibrating your barometer 37

The use of memory hand 38

Barometer Trouble shooting 38

Operating Instruction of Barometer with hinged bezel 39

Operating Instruction of Barometer with fixed glass lens 41

Thermometer & Hygrometer Instructions 44

Thermometer Instruction 44

Hygrometer Instruction 44

Comfortmeter Instruction 45

Clinometer Instructions 47

Installation Instructions

How to install the Instruments with hinged bezel

Suitable for series of

GL 120, GL 150, GL 180, GL 195

1. Stick the **Drill Drawing** supplied on the position where you want to install the instrument on the wall or bulkhead by scotch tape.

Be sure that the transverse line on the drawing overlap with the horizontal line or the vertical line on the drawing overlap with the plumb line.

Please read Additional tips section about How to calibrate Horizontal line or Vertical line

2. Drill the hole marks on the drawing with **3.5mm** drill bit,
3. Remove the drawing from wall or bulkhead.
4. Secure the Instrument with round head stainless steelscrews supplied. Ensure the screws are tight and the instrument is firmly fixed on the wall.

How to install the Instruments with fixed glass lens

Suitable for series of

GL 122, GL 152, GL 198

1. Stick the Drill Drawing supplied on the position where you want to install the instrument on the wall or bulkhead by scotch tape.

Be sure that the transverse line on the drawing overlap with the horizontal line or the vertical line on the drawing overlap with the plumb line.

Please read Additional tips section about How to calibrate Horizontal line or Vertical line

2. Drill the hole marks on the drawing with **2.5mm** drill bit for **GL 122**,
Drill the hole marks on the drawing with **3.5mm** drill bit for **GL 152**,
GL 198.
3. Remove the drawing from wall or bulkhead.
4. Turn the mounting plate on the instrument counter-clockwise and take it off from the instrument.
5. Set the instrument or installing/change battery.
6. Secure the mounting plate with four round head stainless steel screws supplied. Ensure the plate is in correct direction and the screws are tight and the plate is firmly flat against the wall.

Correct Direction of Mounting Plate

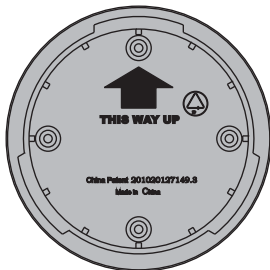

GL 122 Series

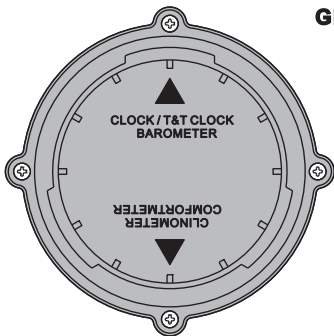

GL 152, GL 198series
Clock/T&T Clock/Barometer

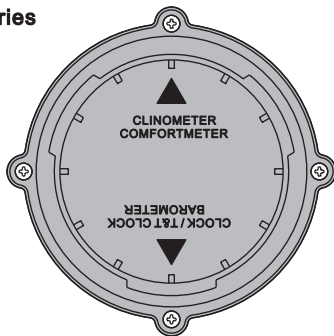

GL 152, GL 198series
Clinometer/Comfortmeter

7. Put the instrument body on the fixed mounting plate, and embed the lug on mounting plate into the gap on the back of the instrument. (The instrument should lean leftwards for about 30 degrees before installing).
8. Turn the instrument body clockwise until it can not be further rotated.

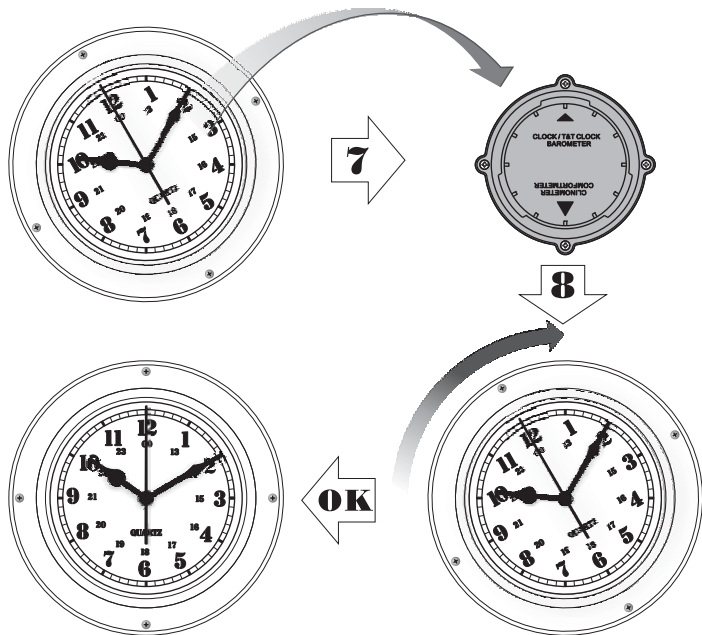

How to calibrate Horizontal line or Vertical line

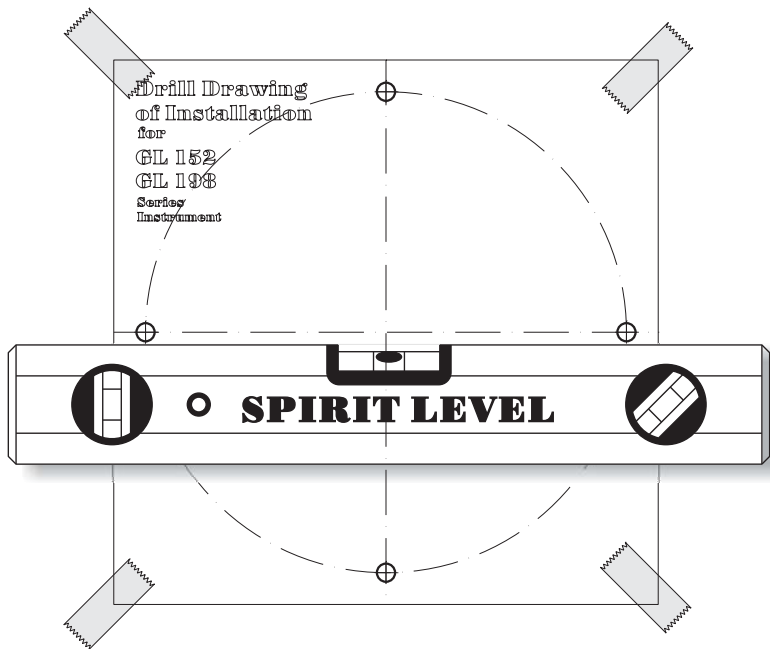

Calibrate Horizontal line by a Spirit Level

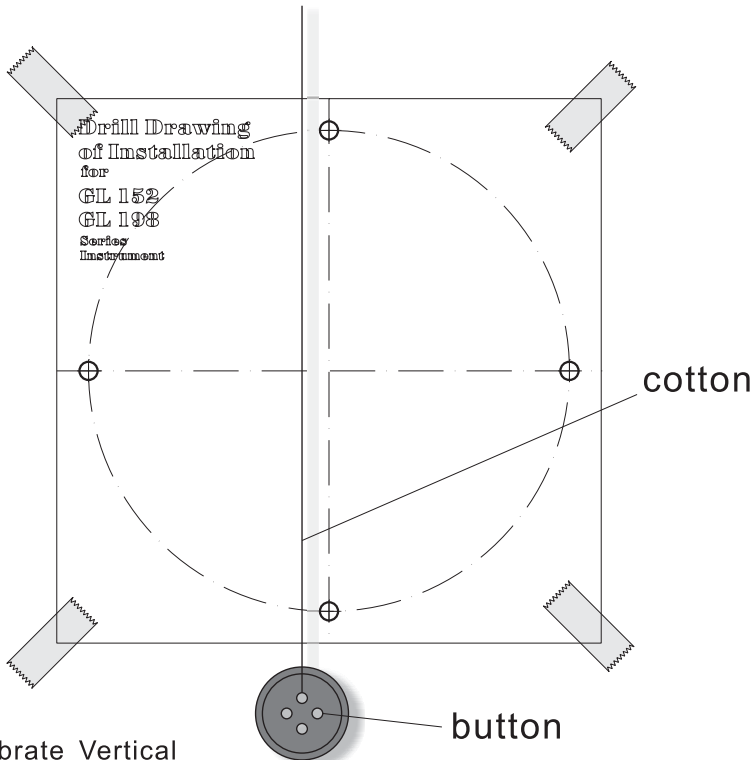

Calibrate Vertical
line by a DIY Plummet

Quartz Clock Instructions

Operating Precautions

Battery

1. Use only alkaline batteries as they have longer life and are less prone to leak.
2. If clock stops, it is most likely due to a dead battery. Remove the battery immediately as it might leak acid causing damage to the movement.
3. If clock is to be left unattended for long periods of time, the battery should be removed. Otherwise it could become dead and leak acid causing damage to the movement..

Note: Movement damage caused by battery leakage will void warranty.

Water Resistance

The following applies to clocks with W/R or W/P marked on the dial or the back of clock

Example of Daily Use	Marking	
	W/R (Water repellent)	W/P (Waterproof)
Semi-outdoor	Yes	Yes
Outdoor	No	Yes
Splashing water	Yes	Yes
Immerged sporadically	No	Yes

Note:

- * Do not use the clock with **W/P** marking for **DIVING INSTRUMENT**.
- * Even if a clock is waterproof, do not operate it while it is submerged in water or wet.
- * After submerged in seawater, use plain water to rinse all salt and dirt from the clock.
- * In order to maintain water resistance, have the gaskets of your clock periodically (about once every two or three years).
- * The inside surface of the clock glass may fog when the clock is exposed to a sudden drop in temperature. No problem is indicated if the fogging clears up relatively quickly. If the fogging does not clear or if water has gotten into the clock, take the clock in for repair immediately.
- * Continued use of the clock with water inside can result in damage to electronic and mechanical components, etc.

Temperature

The operating temperature range of the clock is -10°C~60°C. Temperature extremes can cause the clock to lose or gain time, to stop, or otherwise malfunction.

Vibration

Subjecting the clock to strong vibration can lead to malfunction.

Suggestion: install the rubber shakeproof washer between the clock and bulkhead when it works in occasion with vibration.

Magnetism

The Quartz clock is moved by a motor that uses magnetic force. when such a clock is close to a device that emits strong magnetism, the magnetism can cause timekeeping to slow down, speed up, or stop, resulting in the incorrect time being displayed.

Electrostatic Charge

Exposure to very strong electrostatic charge can cause the quartz clock to display the wrong time. Very strong electrostatic charge even can damage electronic components.

Chemicals

Do not allow the clock to come into contact with thinner, gasoline, solvents, oils, or fats, or with any cleaners, adhesives, paints, medicines, or cosmetics that contain such ingredients.

Storage

If you do not plan to use the clock for a long time, remove battery, wipe it thoroughly free of all dirt and moisture, and store it in a cool, dry place.

Metal Components

Failure to clean dirt from a metal component can lead to decrease of life of the plating on the metal components. You can wipe it with a soft, absorbent cloth periodically. If there are stubborn stains on the surface of metal components, you can wipe it with soft cloth with a little of toothpaste. **Do not use any polishing paste.**

Operating Instructions of Clock with hinged bezel

Suitable for clock series of

GL 120

GL 150

GL 180

GL 195

1. Turn the fastener counter clockwise and wind it to release the hinged bezel.
2. Wind the hinged bezel leftwards to open the clock.
3. Insert an alkaline battery to the back of clock movement. Follow diagram on battery housing to make certain battery is not put in backwards.
4. To set the time, advance hour and minute hands by turning te knob on the back of the movement counter-clockwise. To reverse, turn clockwise.
5. Wind back the hinged bezel after setting time or installing/ changing battery, and turn the fastener clockwise to fix the hinged bezel.

Clock with Hinged Bezel

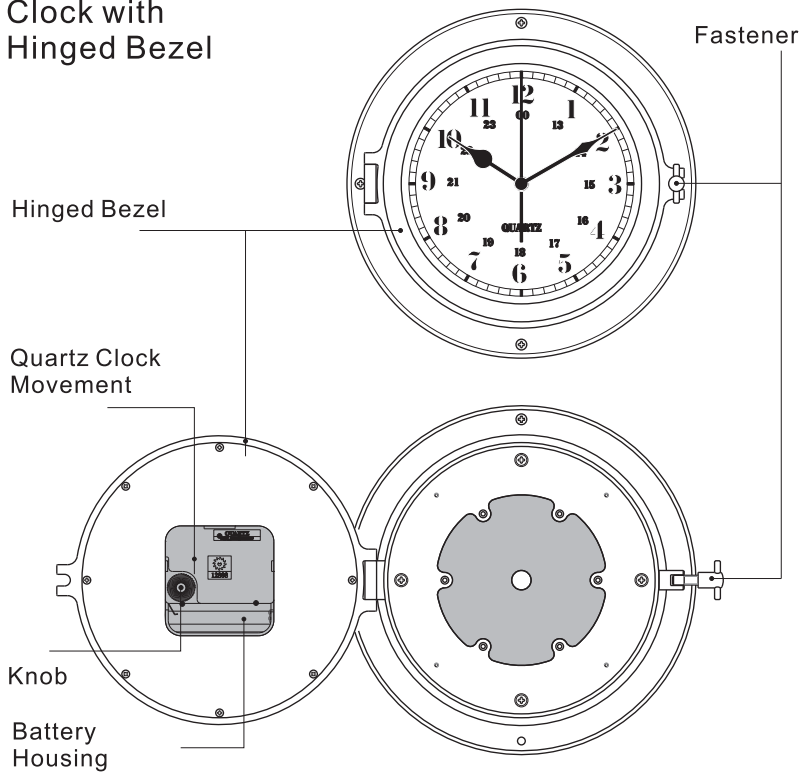

Operating Instructions of Clock with Fixed Glass

Suitable for clock series of

GL 122

GL 152

GL 198

1. Turn the clock body counter clockwise and take it off from the wall or bulkhead.
2. Insert an alkaline battery to the back of clock movement. Follow diagram on battery housing to make certain battery is not put in backwards.
3. To set the time, advance hour and minute hands by turning the knob on the back of the movement counter-clockwise. To reverse, turn it clockwise.
4. Put the clock body on the fixed mounting plate, and embed the lug on mounting plate into the gap on the back of the clock.
(The clock should lean leftwards for about 30 degrees before installing).
5. Turn the clock body clockwise until it can not be further rotated.

Clock with Fixed Glass Lens

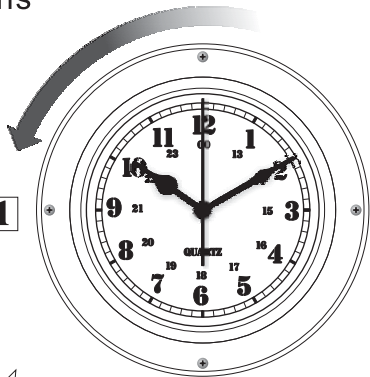
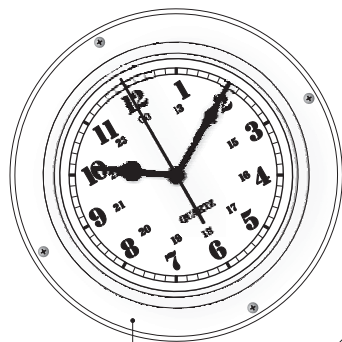

1

1

Clock Body

1

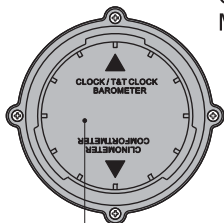

Mounting Plate

Quartz Clock Movement

2
3

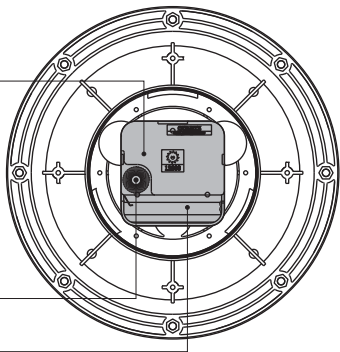

Knob

Battery Housing



4

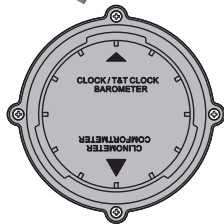

4

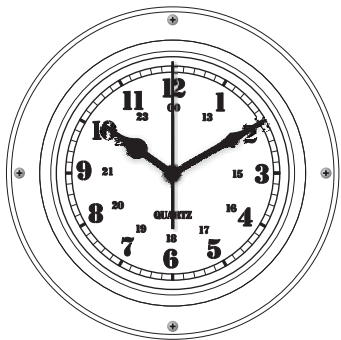

5

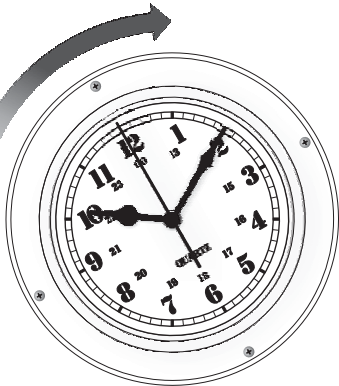

Function Instructions

General Quartz Clock

C1

12 hour Format Quartz Clock
12-24 hour Arabic numerals dial

C2

12 hour Format Quartz Clock
12 hour Roman numerals dial

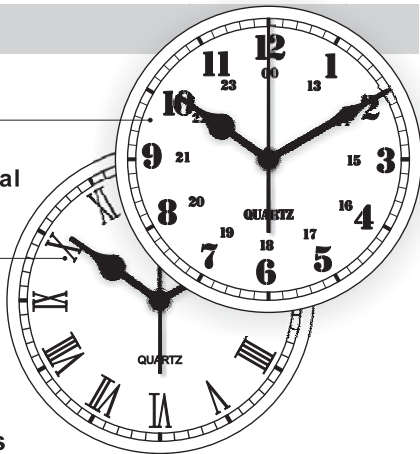

Technical Specifications of Quartz Clock Movements

Operation Voltage	1.3V ~ 1.7V
Time Keeping Accuracy	±30 Sec/Month (1.5V DC, 25°C)
Current Consumption	Less Than 150µA (1.5V DC)
Torque At Second Hand	0.6 (gr-cm)
Torque At Minute Hand	Less Than 36 (gr-cm)
Operating Temperature Range	-10°C ~ 60°C
Battery Life	Approx. One Year (UM-3)
Time Indication	12-Hour Indication By 3 Hands (Analogue)
Time Indication (C4: 24 hours)	24-Hour Indication By 3 Hands (Analogue)

Signal flag numerals dial clock

C 3

12 hour Format Quartz Clock 12 hour Signal flag numerals dial

Signal Flags are one of the oldest forms of communication on the sea. They are used to visually identify ships and send messages through the use of a published book of codes. The following flags are international signals used by ships at sea.



A		K		U		1		1	
B		L		V		2		2	
C		M		W		3		3	
D		N		X		4		4	
E		O		Y		5		5	
F		P		Z		6		6	
G		Q				7		7	
H		R				8		8	
I		S				9		9	
J		T				0		0	

Maritime Signal Flags

Penants

They can be used to spell out short messages, or more commonly, used individually or in combination that they have special meanings. These signal flags are used to communicate while maintaining radio silence. Strung end to end and hung bow to stern from the rigging they are used to dress the ship for ceremonial and festive occasions.

24 Hour Time/Military Time Clock

C4

24 hour Format Quartz Clock
24 hour Arabic numerals dial

24-Hour Time

The 24-hour clock is a convention of time keeping in which the day runs from midnight to midnight and is divided into 24 hours, indicated by the hours passed since midnight, from 0 to 23.

In many regions of the world, the time of day is customarily given almost exclusively using the 12-hour clock notation, which counts the hours of the day as 12, 1, ..., 11 with suffixes 'a.m.' and 'p.m.' distinguishing the two diurnal repetitions of this sequence.

Although 12-hour time is mostly used in speech for ease of use, and 24 hour time is preferred in writing. In some specialist areas (military,

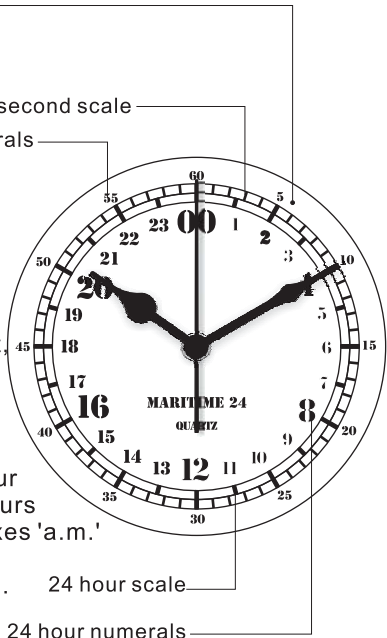

aviation, navigation, meteorology, astronomy, computing, logistics, emergency services, hospitals) the 24-hour clock is generally used as it prevents any ambiguity.

The 24-hour notation is also popularly referred to as military time or astronomical time. In some parts of the world, it is called railway time or continental time. It is also the international standard notation of time (ISO 8601).

Military time

The world is divided into basically 24 time zones. When it comes to operational matters (such as communications, training exercises, deployments, ship movements aircraft flights, etc.), the military must often coordinate with bases and personnel located in other time zones. To avoid confusion, in these matters, the military uses the 24 hour time in Greenwich, England, which is commonly called Greenwich Mean Time (GMT). For easy reference in communications, a letter of the alphabet has been assigned to each time zone. The time zone for Greenwich, England has been assigned the letter "Z." That is why the military call this time -"Z Time".

24-hour clock	12-hour clock
00:00	12:00 a.m. (start of day) "12 midnight"
01:00	1:00 a.m.
02:00	2:00 a.m.
03:00	3:00 a.m.
04:00	4:00 a.m.
05:00	5:00 a.m.
06:00	6:00 a.m.
07:00	7:00 a.m.
08:00	8:00 a.m.
09:00	9:00 a.m.
10:00	10:00 a.m.
11:00	11:00 a.m.
12:00	12:00 p.m. 12 noon.
13:00	1:00 p.m.
14:00	2:00 p.m.
15:00	3:00 p.m.
16:00	4:00 p.m.
17:00	5:00 p.m.
18:00	6:00 p.m.
19:00	7:00 p.m.
20:00	8:00 p.m.
21:00	9:00 p.m.
22:00	10:00 p.m.
23:00	11:00 p.m.
24:00	"12 midnight" (end of day)

Radio Room Clock

C5

12 hour Format Quartz Clock Radio Room Clock dial

2182 kHz Silence Period (green)
at 0-3 & 30-33 minutes

Four-Second dash (red)
timing marker

500 kHz Silence Period (red)
at 15-18 & 45-48 minutes

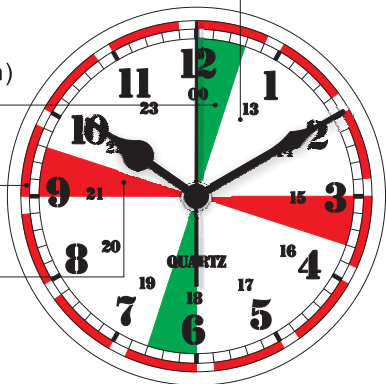

All Radio stations on ship using 2182 kHz are required to maintain a strictly enforced three-minute silence and listening period twice each hour, starting at h+00, h+30. This allowed any station with distress, urgent or safety traffic the best chance of being heard at that time, even if they are at some distance from other stations, operating on reduced battery power or perhaps reduced antenna efficiency, as for example from a dismasted vessel.

As a visual aide-memoire a typical clock in a ship's radio room would have these silence periods as follows:

2182 kHz Silence Period at 0-3 & 30-33 minutes

marked by shading the sectors from h+00 to h+03 and from h+30 to h+33 in green.

(no calls transmitted) which must be observed by all radio stations beginning at each hour and half hour, for the purpose of listening for any distress calls sent by radio telephone (Voice) at a radio frequency of 2182 kilohertz.

500 kHz Silence Period at 15-18 & 45-48 minutes

marked by shading the sectors from h+15 and h+18 and from h+45 to h+48 in red.

(no signals transmitted) which must be observed by all radio stations beginning at 15 and 45 minutes past each hour, for the purpose of listening for any distress calls sent by radiotelegraph (International Morse Code) at a radio frequency of 500 kilohertz.

Four-Second dash timing marker

The 4 second marks in red around the outside edge of the minute track over which the sweep-second hand passes, enables the radio operator to accurately transmit the 4 second alarm signal provided by the International Telecommunications Convention and the International Conference of Safety of Life at Sea (SOLAS).

Time & Tide Clock

T/T

Time & Tide Clock
12 hour Arabic numerals dial
with tide indication

WARNING:

DO NOT RELY ON THIS PRODUCT FOR TIDE INFORMATION IF THERE IS A CHANCE FOR DAMAGE, LOSS OR INJURY RESULTING FROM IMPROPER TIDE INFORMATION. THIS PRODUCT USES THE LUNAR TIDE CYCLE TO DISPLAY TIDE CONDITION.

“Tides” are the rise and fall of ocean waters in response to the forces exerted predominately by the moon. The moon creates two tidal bulges on earth, one at the closest and one at the farthest point from the moon. The earth rotates through these two tidal bulges every lunar day. A lunar day is 24 hours and 50 minutes. This is due to the fact the moon revolves around the earth in the same direction that the earth rotates around its own axis.

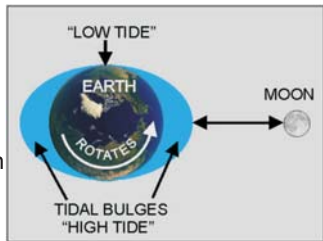

THERE ARE A NUMBER OF FACTORS WHICH CAUSE VARIATIONS IN THE TIDAL CYCLE:

1. The sun also generates tidal forces, but they are much smaller and are considered to be variations of the lunar tides.
2. The large continental land masses block the westward travel of the tidal bulge and cause complex tidal cycles in ocean basins that can differ greatly from adjacent basins.
3. Ocean floor topography, bays or narrow inlets can all cause resonance effects, altering the tidal cycle.

THESE FACTORS LIMIT THE AREAS WHERE THIS PRODUCT CAN BE USED TO DISPLAY TIDE CONDITION ACCURATELY. (SEE MAP BELOW)

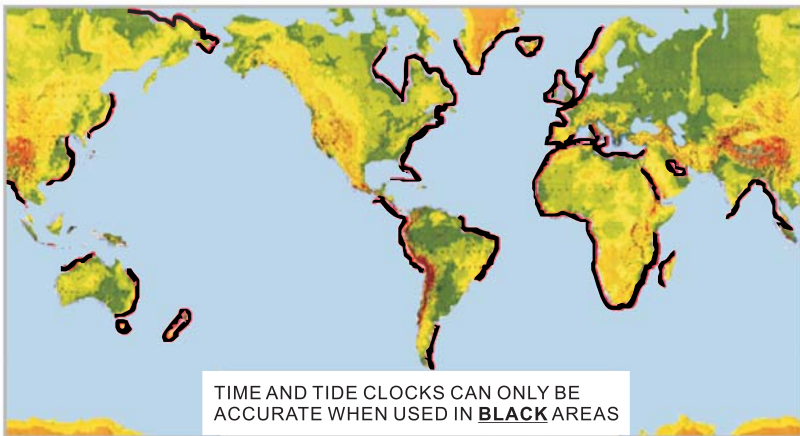

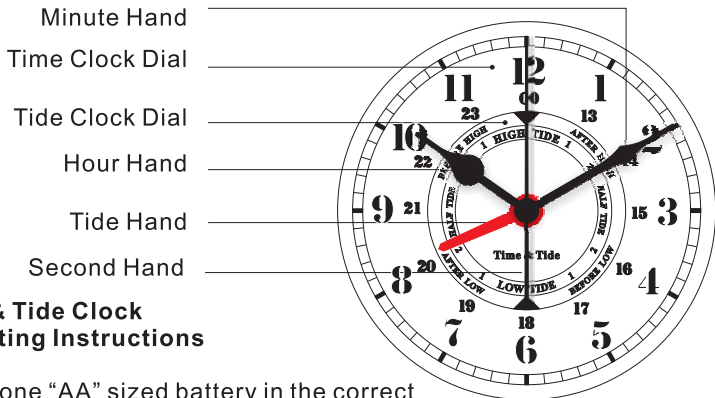

Time & Tide Clock Operating Instructions

Install one “AA” sized battery in the correct direction. If the battery is reversed, the clock will not function.

How to Set a Time & Tide Clock

FIRST – Adjust the hour and minute hands to the correct time using the time adjustment wheel on the back of the clock.

SECOND – Align the RED tide hand using the tide adjustment wheel according to your local tide information.

FOR BEST RESULTS
– SET TO “HIGH TIDE” DURING A
FULL MOON OR NEW MOON PHASE.

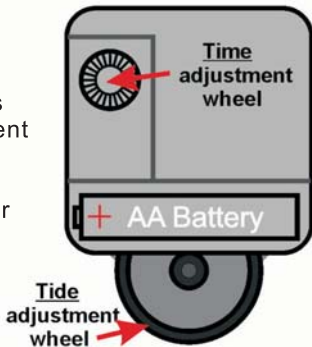

Barometer Instructions

General Instructions

The atmospheric pressure is produced by the air surrounding our planet; it changes on a daily or even hourly basis, as well as seasonally. This is due to the normal day/night cycle of solar insolation, and also due to local weather patterns.

Typically, low pressure centers form over warm regions, and cold areas can develop high pressure centers. Low pressure centers can produce bad weather and high pressure centers are usually associated with calm weather and no precipitation.

Atmospheric pressure can be measured by barometer, and the changes in atmospheric pressures on barometers can supply us the reliable data for weather forecasts.

Note: The barometer will normally indicate changes in weather 12 to 24 hours in advance. It is not an indicator of present weather conditions.

Warning: As there are many other variables to consider aside from air pressure, not every low pressure center will cause bad weather, and not every high pressure center is immune to bad weather. So,

DO NOT RELY ON THIS PRODUCT FOR WEATHER INFORMATION IF THERE IS A CHANCE FOR DAMAGE, LOSS OR INJURY RESULTING FROM IMPROPER WEATHER INFORMATION. PLEASE GET EXACT WEATHER INFORMATION FROM THE LOCAL OFFICIAL WEATHER STATION.

Specification of the barometer movement

Size: $\Phi 60\text{mm} \times 23\text{mm}$

Material: Brass, Iron

Measurement Range: 960~1060hPa

Precision: 990~1030 hPa: $\pm 3\text{hPa}$

960~990 hPa/1030~1060 hPa: $\pm 5\text{hPa}$

The barometer measures the atmospheric pressure in kPa/ inch Hg or hPa/ mm Hg.

Other units are also used in measuring atmospheric pressure, here's some additional explanation for these units.

1 standard atmosphere	by definition
101325 pascals	by definition
101.325 kilo pascals	1 kilo pascal = 1000 pascals
1.01325 bars	1 bar = 100,000 pascals
1013.25 millibars	1 millibar = 1/1000 bar
760 Torrs	by definition
29.9247 inches of mercury	weight of a mercury column
14.696 psi	measurement in pounds per square inch

Note:Your barometer is an aneroid type which measures atmospheric pressures mechanically without use of liquids.

Note:Do not take any notice of the words Rain, Change, Fair, Storm. They are there only as a traditional graphic decoration.

Instructions of calibrating your barometer

When your barometer left the factory, it was set at the standard air pressure of factory's local altitude. To be able to compare the air pressure readings between locations of different local altitude it is essential to eliminate the pressure differences which are caused by the different local altitudes. If the barometer is meant to show the correct relative air pressure for each and every location it has to be adjusted once to adapt to local altitude.

How to adjust your barometer to your local altitude?

1. Get the current relative air pressure value for your location. please check with your local newspaper, your local radio station at that day.
2. Operating your barometer according to the Barometer Operating Instructions to find the adjustment screw on your barometer.
3. Turn the adjusting screw by a small screwdriver carefully to set the barometer hand to the correct air pressure value for your location.
*Better precision can be achieved by lightly tapping the barometer glass after adjustment has been made.

Warning: In order to avoid the inner parts damage, please avoid making the barometer hand move too far and too quickly. It is recommended to adjust the screw in steps.

*Never turn this screw in either direction more than one full rotation.

The Use of the Memory Hand

The Memory Hand at the center of the glass lens should be set to the present atmospheric pressure and superpose the barometer hand. This will allow you to remember the atmospheric pressures after some time has passed, and determine if the atmospheric pressure is on the “Rise” or “Fall”.

Barometer Troubleshooting

Barometer hand will not move

- A. Wait for a few days, in case the pressure is steady.
- B. Place barometer in a clear, plastic bag trapping air inside with the barometer. Hold opening of bag closed and push on bag which should create air pressure causing the needle to move.
- C. If A & B is not able to resolve the problem, return the barometer to repair.

Barometer hand showing incorrect reading

- A. Tapping the barometer glass lightly and review the reading
- B. Adjust the adjustment screw in the back of the movement, turning either left or right to bring the hand to the correct reading. Never turn this screw more than one rotation.
- C. If A or B is not able to resolve the problem, return the barometer to repair.

Operating Instructions of Barometer with hinged bezel

Operating Instructions for Barometer series of GL 180, GL 195

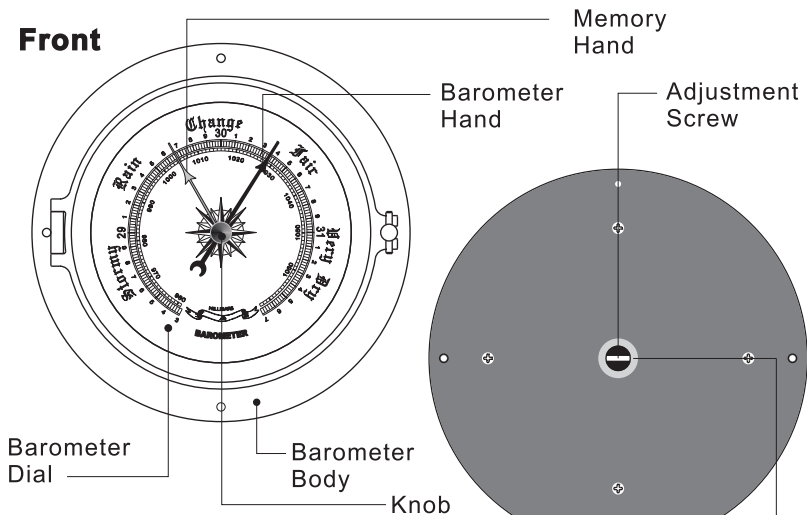

Turn the adjustment screw in the hole which is on the backside of the barometer by a small screw driver carefully until the pointed value coincides with the actual atmospheric pressure.

Backside

Operating Instructions for Barometer series of GL 120, GL 150

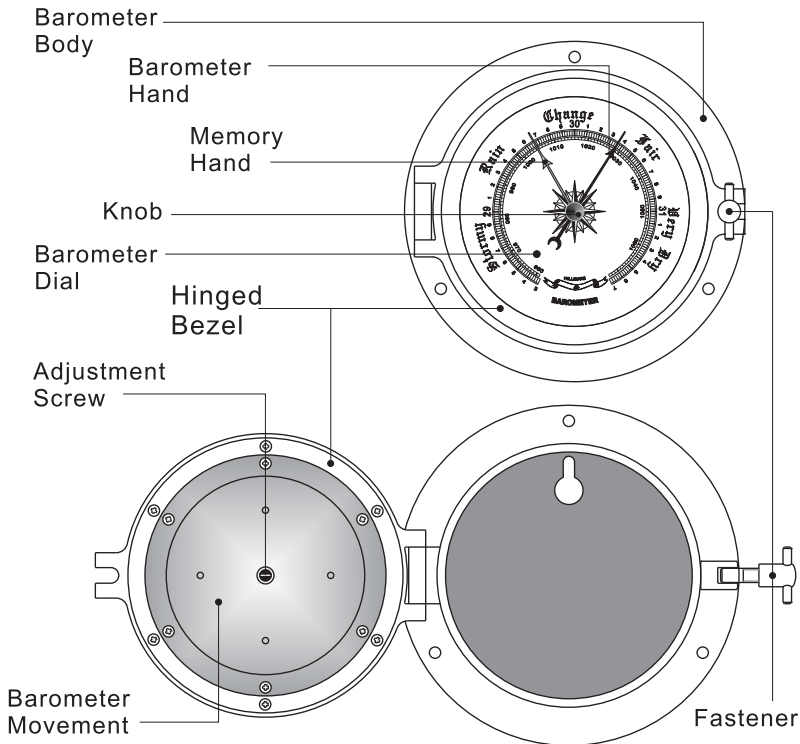

1. Turn the fastener counter clockwise and wind it to release the hinged bezel.
2. Wind the hinged bezel leftwards to open the barometer.
3. Turn the adjustment screw by a small screw driver carefully until the pointed value coincides with the actual atmospheric pressure.
4. Wind back the hinged bezel after adjustment, and turn the fastener clockwise to fix the hinged bezel.

Operating Instructions of Barometer with Fixed Glass lens

Suitable for series of
GL 122, GL 152, GL 198

1. Turn the barometer body counter clockwise and take it off from the wall or bulkhead.
2. Turn the adjustment screw by a small screw driver carefully until the pointed value coincides with the actual atmospheric pressure.
3. Put the barometer body on the fixed mounting plate, and embed the lug on mounting plate into the gap on the back of the instrument. (The barometer should lean leftwards for about 30 degrees before installing).
4. Turn the barometer body clockwise until it can not be further rotated.

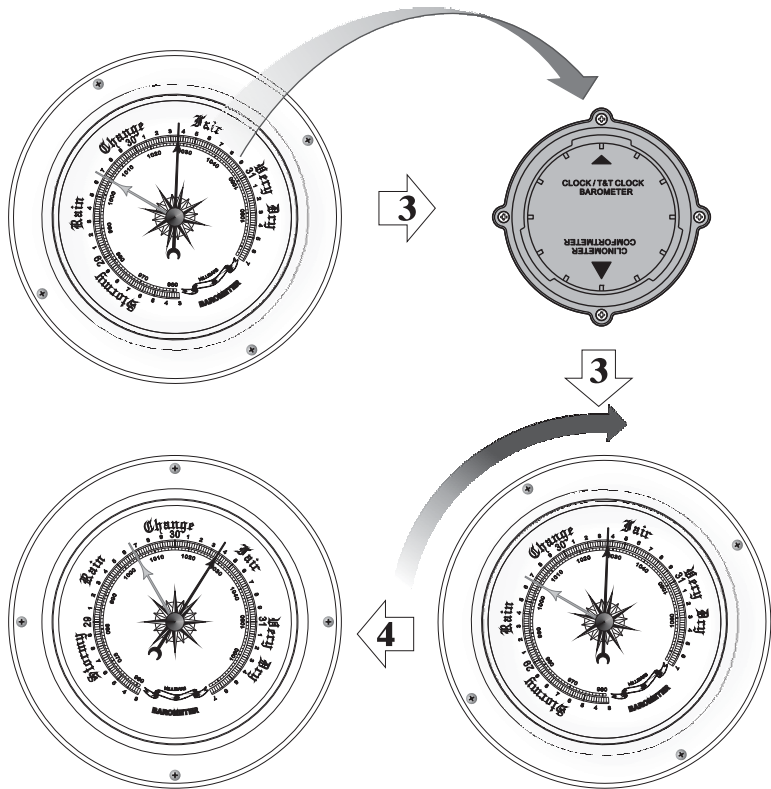

Thermometer & Hygrometer Instructions

Thermometer Operating Instructions

A bimetal thermometer works on the principle that different metals contract and expand to different degrees when exposed to temperature changes.

Range	-20~50°C / -4~122 °F
Tolerance	+/-2°C

Note:The thermometer had been pre-adjusted and calibrated in a temperature controlled environment at factory. Do not adjust it by laypeople.

Warning:The thermometer will be damaged if overtopping the working range.

Hygrometer Operating Instructions

The Hygrometer will indicate the relative humidity of the atmosphere. While indoor and outdoor barometric pressure is identical, it is not true of the relative humidity. Therefore, remember that this instrument when used in the home indicates the humidity of room atmosphere which has no relation to the outdoor humidity readings announced on weather reports.

Range	20~90%RH
Tolerance	+/-9

Readjustment of the Hygrometer

If a hygrometer is exposed to very dry air over a longer period of time and if you would like to maintain a correct reading, we recommend you to readjust the instrument every 3-4 months.

Put a damp cloth on the back of the hygrometer for about an hour to allow humidity to get into the instrument and circulate within the case of the hygrometer. After that period of time the scale should read approximately 95 %. The humidity indicator will then start to operate again. To maintain accuracy of the instrument, it is advisable to repeat this procedure every 3-4 months.

Comfortmeter Operating Instructions

This Comfortmeter is a combination of both temperature and humidity indicators. Calibration and positioning of hands are designed to indicate perfect comfort conditions when both hands cross in a limited area of the dial, the **COMFORT** zone.

Note: Both temperature and humidity indicators are accurately calibrated at the factory and normally require no adjustment.

Note: To maintain accuracy of Hygrometer, it is advisable to readjust the hygrometer in comfortmeter according to above instructions every 3-4 months.

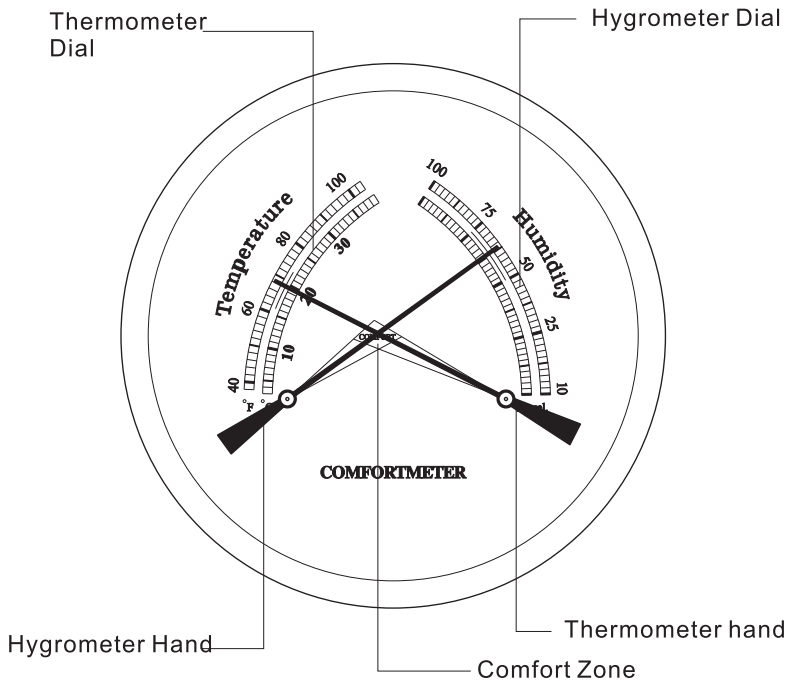

Comfortmeter

Clinometer Operating Instructions

Clinometer is the instrument used on ships to measure how much a vessel slants while on still water and when the water is choppy.

Measuring the tilting of a ship is of utmost importance. With the help of clinometers, it becomes easier to find whether the tilting of the ship is dangerous or within the danger-free limits.

Measuring Range	-50~50 DEG
Tolerance	+/-1.5 DEG

The clinometer is a mechanical instrument without fluid or bubble which enables it to provide superior performance in full sun and wide temperature extremes.

The surface engineering - low friction movement need not any lubricating oil or damping agent to avoid block or moving slow when exposed to temperatures below freezing for long periods.

Note: Be sure that the clinometer is installed according to the **Installation Instructions**, and calibrate horizontal line or vertical line carefully when install it, otherwise its accuracy will be influenced.

Note: Do not use any lubricating oil for your clinometer, otherwise it will be blocked or moving slow when exposed to temperatures below freezing.

WARNING: THE CLINOMETER DEALS WITH THE SAFTY OF THE SHIP. IT MUST BE PAIED CLOSE ATTENTION TO AND CHECKED OR VERIFIED AT FIXED PERIOD. IF THERE ARE ANY INACCURATE READING OR FAULTS, THE CLINOMETER MUST BE PUT OUT OF USE AND EXAMINED BY PROFESSIONAL.

How to Operate the Fixing Screw and Release The clinometer

To prevent the clinometer from being damaged during transit, the movement is fixed by a special screw, which must be loosen or taken off when the clinometer is to starting working.

As there are many types of clinometer which have different structures, the fixing screws accordingly have different types and their operating methods are divided in two kinds as follows:

1. Loosening off

Suitable for below types:

GL120-CL;

GL122-CL;

GL150-CL;

GL152-CL;

GL198-CL.

For above type of clinometer, you can find a black grub screw on the back of the clinometer movement, turn it counter-clockwise by a small screwdriver and take it off from the clinometer, then your clinometer will start working.

GL 120-CL

GL 150-CL

Clinometer Body

Clinometer Hand

Clinometer Movement

Fixing Screw

Hinged Bezel

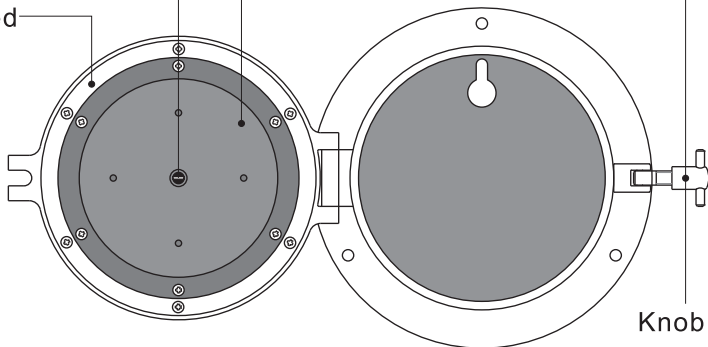

Knob

Clinometer Body

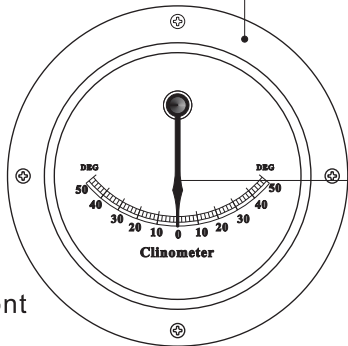

Front



Clinometer Hand

Mounting Plate Hand

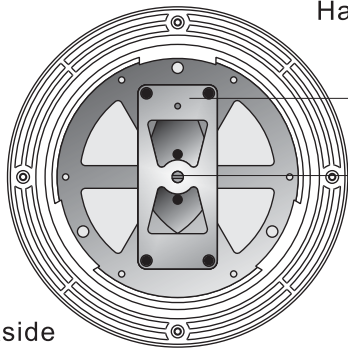

Clinometer Movement

Fixing Screw

Backside

GL 122-CL

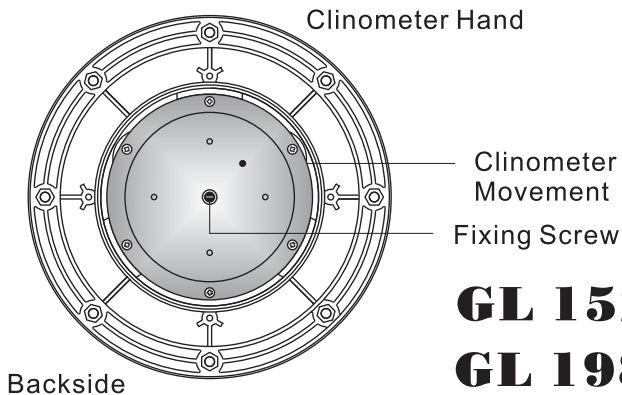
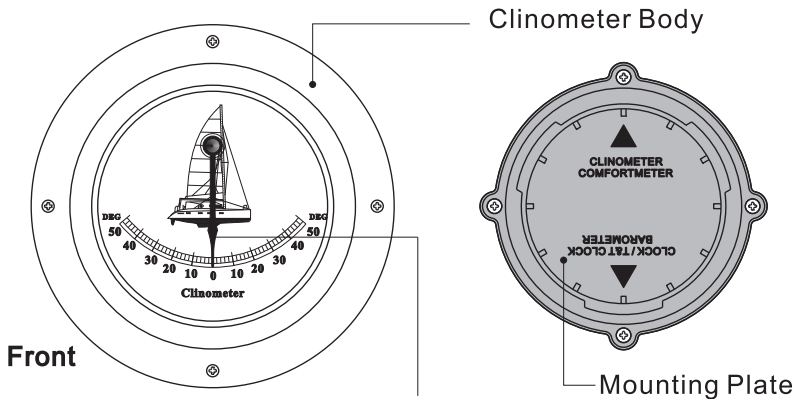

GL 152-CL
GL 198-CL

2. Loosening but Hold on

Suitable for below types:

GL195-CL;

GL180-CL.

For above type of clinometer, you can find a slotted screw in a hole on the back of the clinometer, turn it counter-clockwise by a small screwdriver until it can not be rotated, then your clinometer will start working.

